

RV-8200R

AMAC Rotary Vacuum Packing Machine

Main components:
8 Station Rotary Vertical Bag Feeder With Bag Opener
10 Station Rotary Vacuum Chambers
Water cooling system

QUICK FACTS



FULLY AUTOMATIC
LOADING OF PRODUCTS,
DRY OR LIQUID



FOR FLAT POUCH, STAND-UP
POUCH, GUSSETED BAGS, AND
LAMINATES



STAINLESS-STEEL CONSTRUCTION



WIDELY USED IN PROCESSED
FOOD CONSUMER PACKAGING

RV-8200R SERIES

AMAC Rotary Vacuum Packing Machine

FULLY AUTOMATED

Vacuum Packaging System

For flat pouch, stand-up pouch, gusseted bags and laminates

Specification Table

FEATURES	RV-8200R
Size Of Bag	W:120-200mm L: 150-300mm
Filling weight	20 to 1000g
Speed	Up to 35 BPM
Total Power	5.5kW
Compress Air Requirement	≥ 0.6 m ³ /min supply by user
Weight	3000kgs
Dimension	2600*1900*1700mm(L*W*H) see footprint below:

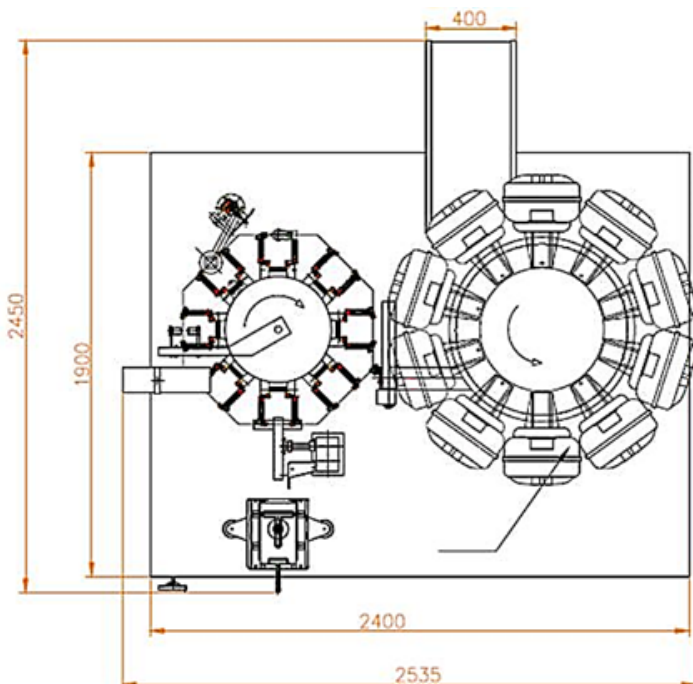

Product size: Please consult AMAC sales.

Machine Features:

1. Machine motion and sequence control with PLC. HMI with color display.
2. Filling machine rotates intermittently to fill the product with ease. Vacuum rotary rotates continuously.
3. Filling machine accommodates wide variety of products and needs to choose proper funnel for the different types of products. The chamber(Clam shell) on the other hand, stays the same size and no need to change components.
4. Filling zone and vacuum chambers are washable.

Safety and alarm system:

1. No bag – no filling, no sealing, machine alarm
2. Bag opening miss- no filling-no sealing, machine alarm
3. Machine stop or alarm when the air pressure is abnormal
4. Error position display at the control panel
5. Machine housing and all the parts which touch products are made of 304 stainless steel.
6. Some safety doors are made of aluminium frame.
7. The doors are equipped with safety proximity sensors
8. Machine surface can be washed and scrubbed.



AMAC's machines are simple and robust vacuum packing machines with a world-wide reputation.

Pouch type

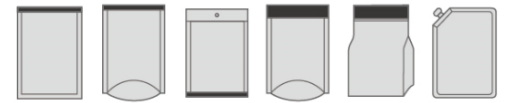

All features available in the series



Product Specs and Applications

Not sure which solution fits your business needs? Contact us to learn more about this and any other product in our series.